

Model 700-15



Model 700-15 - Horizontal, double web pouch machine

The Model 700-15 Econo-Pak Cold Seal Machine is best suited for smaller run packaging applications in the printing, automotive, medical, building products and light manufacturing industries. Its flexibility is specialized especially for distributors and firms engaged in direct mail operations.

The 700-15 is applicable for use with paper, polyethylene, single-face corrugated material, cohesive microfoam, cohesive air cap or any combination of these cohesive media.



SYSTEM PACKAGING

Model 700-15

SPECIFICATIONS

Model	DIMENSIONS			MAXIMUM SPEED (units per minute)	PACKAGE SIZE (ADJUSTABLE)		ELECTRICAL REQUIREMENTS	AIR REQUIREMENT
	L	D	H		Min.	Max.		
700-15	77"	66"	36"	Up to 20	6" x 6"	15" x 16"	115 VAC 1 Phase 5 amp	80 PSIG

- ▶ Hand-feed or automatic operation with delivery rates of up to 20 pouches per minute
- ▶ Cold seal system eliminates heating elements, high electrical consumption and ventilation problems
- ▶ No warm-up or cool-off time
- ▶ Casters available

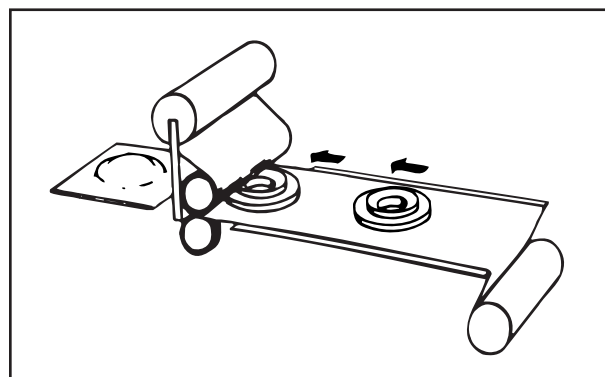

WEBS

- ▶ Paper – Paper
- ▶ Paper – Corrugated
- ▶ Corrugated – Corrugated
- ▶ Poly – Poly
- ▶ Poly – Corrugated
- ▶ Cohesive Microfoam
- ▶ Poly – Paper
- ▶ Cohesive Air Cap



SYSTEM PACKAGING

28905 GLENWOOD ROAD • P.O. BOX 109
PERRYSBURG, OHIO 43552-0109
419/666-9712 • FAX 419/666-8072
E-MAIL: sales@systempackaging.com

A Division of Glassline Corporation

