

Model CH-45

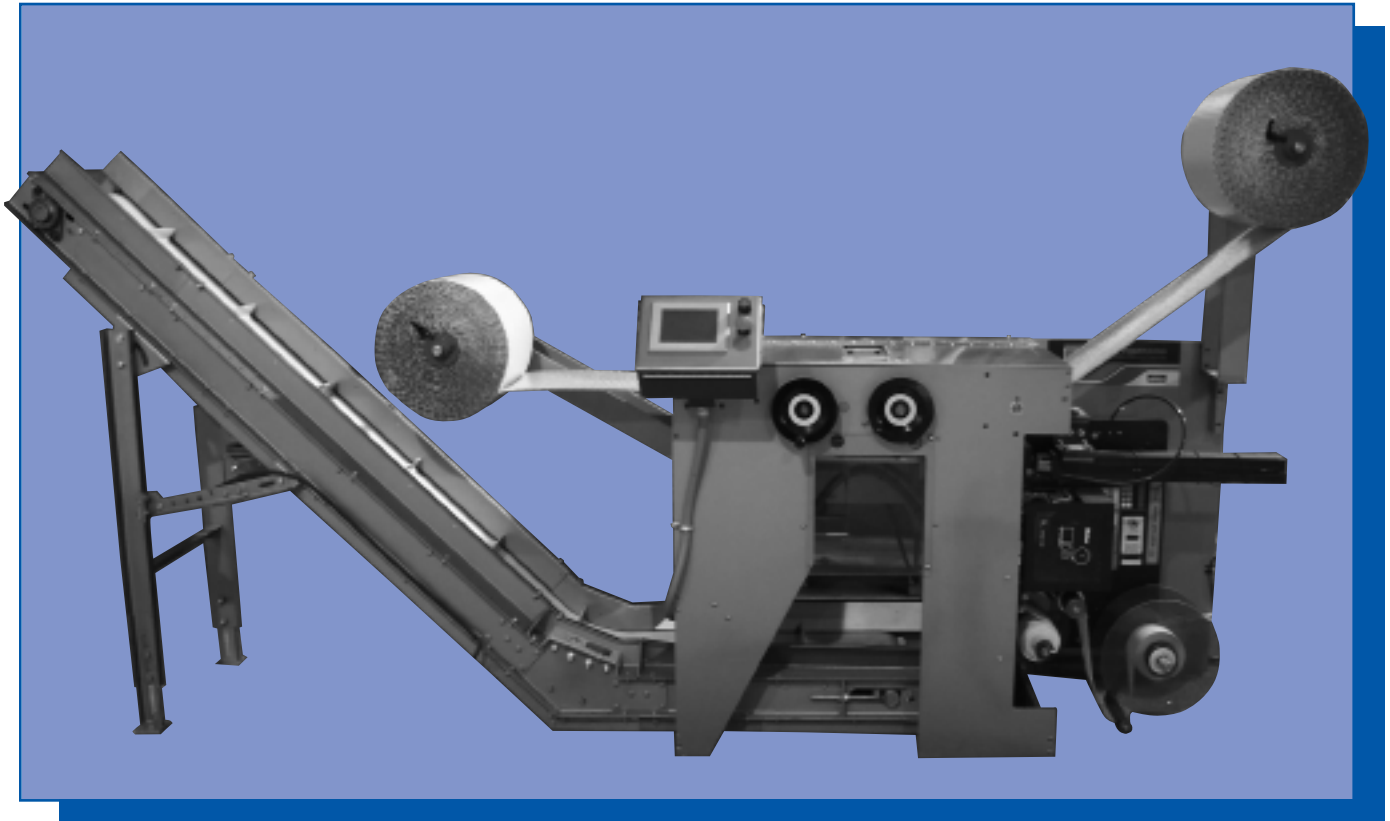

Model CH-45* - Cold/Heat Seal System for a unique packaging solution

System Packaging has combined its versatile, high-quality double web pouch machine (the Model 4500) using strip coated bubble or polyethylene with a heat seal cut-off, to produce packages that don't mold to the product shape, can have easy-open feature, and are easily returned - providing the extra value-added service your customer's will appreciate.

The CH-45 easily produces 15 to 20 packages per minute using just one operator, and can make various mailer lengths on the fly. This system also allows you to stock rolls versus boxes, for additional cost savings and increased warehouse space.

The perfect system for packaging:

- ▶ Jewelry
- ▶ Cosmetics
- ▶ Nutraceuticals / Pharmaceuticals
- ▶ Books / DVD's / CD's
- ▶ Small Parts

*Patent Pending



SYSTEM PACKAGING

Model CH-45*

SPECIFICATIONS

Model	DIMENSIONS			MAXIMUM SPEED (units per minute)	PACKAGE SIZE (ADJUSTABLE)		STANDARD ELECTRICAL REQUIREMENTS
	L	D	H		Min.	Max.	
CH-45	52"	34"	37 ³ / ₄ "	15 to 20	3" x 3"	12" x 20"	220 - 440 volt / 60 hz. / 20 AMP
CH-45-15	55"	34:	37 ³ / ₄ "	15 to 20	3" x 3"	15" x 20"	220 - 440 volt / 60 hz. / 20 AMP

*Also requires an 80 PSIG Air Connection

FEATURES

- ▶ Touch Screen Controls
- ▶ Standard 12" maximum width, 15" also available
- ▶ Forms pouches as deep as 3-1/4"
- ▶ No warm-up or cool-off time required
- ▶ No special ventilation problems
- ▶ Easy length control via Touch Screen

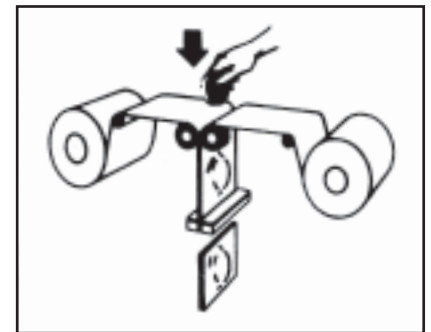

OPTIONS

- ▶ Random length cutoff
- ▶ Electric eye cutoff
- ▶ Print and apply labelers, for direct package labeling
- ▶ Batch Counter
- ▶ Incline Conveyors to remove packages
- ▶ No product/No Package Sensor
- ▶ Casters

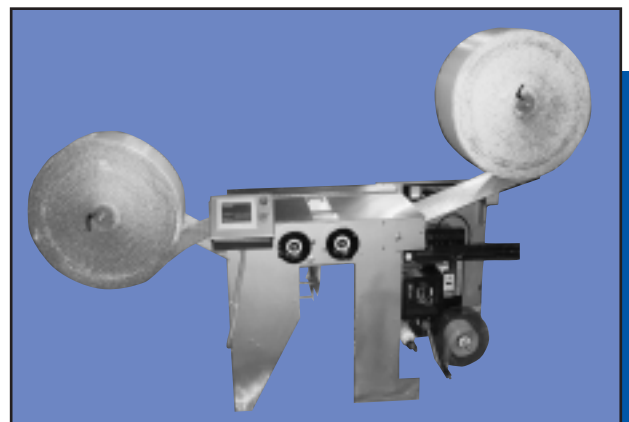

WEBS

- ▶ Air Cap Bubble
- ▶ Poly - Poly

*Patent Pending



SYSTEM PACKAGING

28905 GLENWOOD ROAD • P.O. BOX 109
PERRYSBURG, OHIO 43552-0109
419/666-9712 • FAX 419/666-8072
E-MAIL: sales@systempackaging.com

A Division of Glassline Corporation

